



# Tip Of The WEEK

[www.dchome1.com](http://www.dchome1.com)

## Water Lines & Drain Pipes

PLUMBING

You probably never thought about it, but they're there. Water lines and drain pipes run through the walls, ceilings, and floors in every home. There is a major water delivery and waste system hidden within your walls. Now it's a home inspectors job to evaluate this hidden system.

A home inspector can only speculate on the condition of hidden pipes by what he finds visible under sinks, in the bathrooms, and in the basement areas. These pipes may be very rusted or corroded but doing what is expected of them... delivering water or removing waste. If this is the case, a home inspector will have to state that the system is serviceable, and can only suggest future repairs or upgrades may be needed.

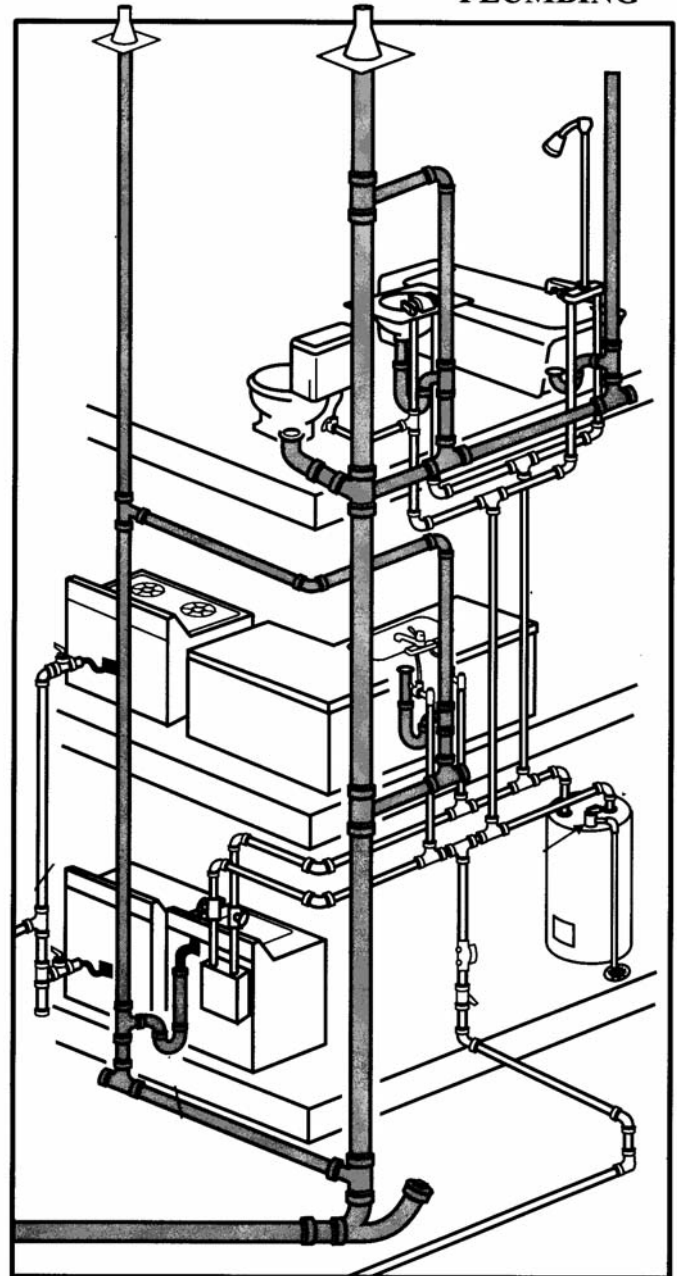

Akron (330) 733-6707

Canton (330) 494-8900

Fax (330) 733-0050

REVEALED THE SECRETS